

*

(// : // :)

(rpm)
) rms
(
rms
 a_{hv}
rms :

Paddan & Griffine .(Salokhe et al., 1995)

()

ISO

Paddan &)

Temmerman et al.

.(Griffin, 2002

()

.(Tewari et al., 2004)

()

Salokhe et al.

() Marsili et al.

() Hansson .

Salokhe .

() et al.

(MITSUBISHI, 7.7hp-2400rpm)

()

() Goglia et al.

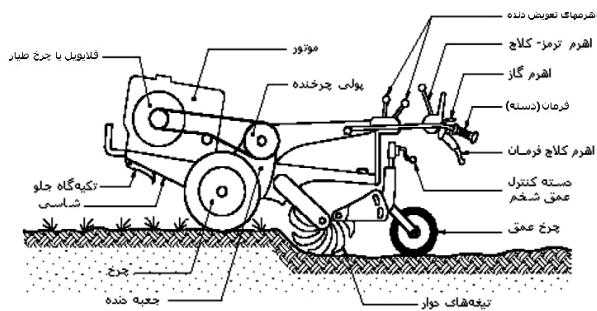

() Kumar et al.

ISO

() Ragni et al. .

()

)

(

(DIGITAL PHOTO/CONTACT
 TACHOMETER, Lutron DT-2236, 0.5-100,000
 RPM, Accuracy: $\pm(0.05\%+1\text{digit})$, Made in
 Taiwan)

٤
 (TSV-01)

TV 300

()

.(Rossegger & Rossegger, 1960)

kHz Hz

PC

() Salokhe et al.

rms

rms

$$a_{hv} \quad \text{rms} \quad \text{(CRD)}$$

() : (ISO 5349-1, 2001)

$$a_{hv} = \sqrt{a_{hvx}^2 + a_{hvy}^2 + a_{hvw}^2} \quad ()$$

ISO 5349-2 ISO 5349-1

(Rao, rms (FFT) .1995)

$$() \quad () \quad ()$$

() (Inman, 1989)

:(Barber, 1992)

$$a_{rms} = \sqrt{1/T \int_0^T a^2 dt} \quad (1)$$

a T rms a_{rms} t

()

rms

a_{hwz} a_{hwv} a_{hwv} z y x

(ISO 5349-1, 2001; ISO 5349-2, 2001)

6. Vibration Total Value
7. Handle Grip

1. MSTATC
2. Excel 2003
3. SPSS 13
4. Frequency Analysis
5. MATLAB 7



()

Hz

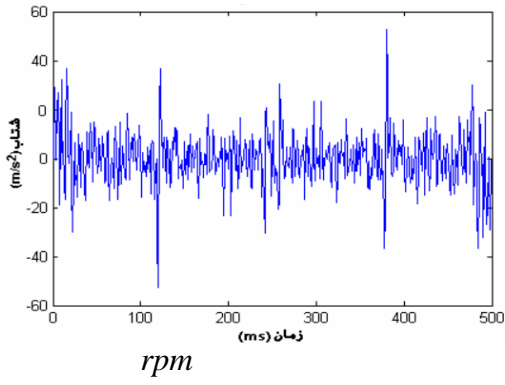

()

()

()

)

(

()

rpm

Hz

/ Hz

/ Hz

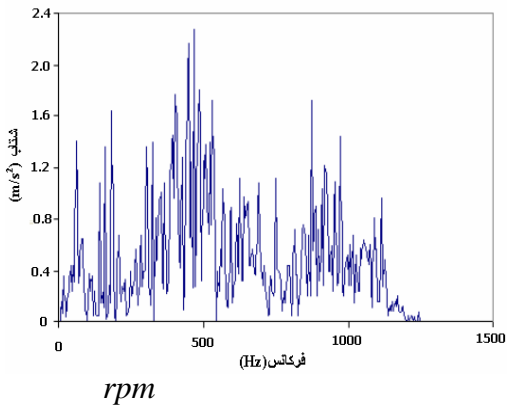

()

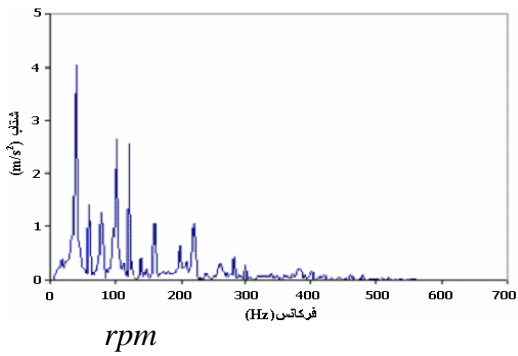
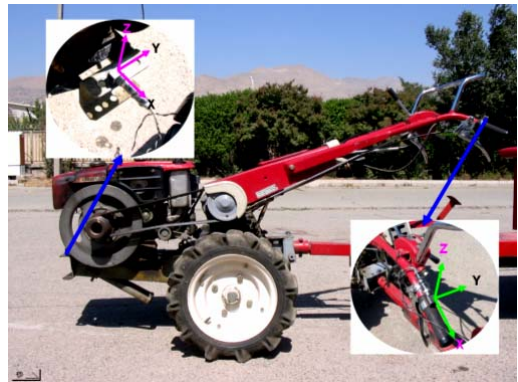

()

()

Hz

()

(FFT)

()

rpm

... :
 () ()
 Hz / Hz

()

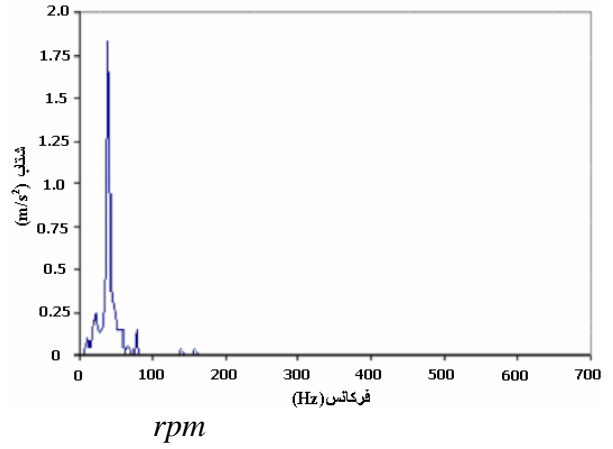

() Salokhe et al.

() rpm
 Hz
 rpm / sec () = Hz

() rms rpm ()

rms
 (CRD)

%

()

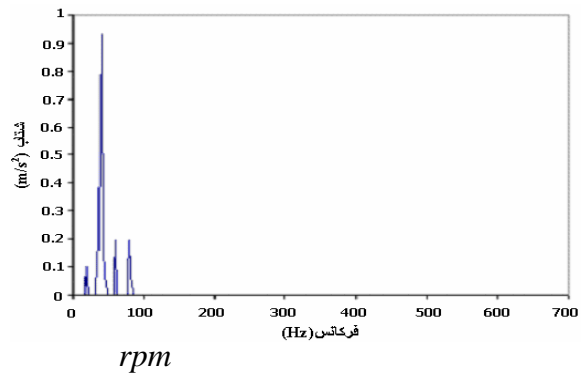

%

(×)

(%)

/ **	/ **	/ **	/ **	/ **
/ **	/ **	/ **	/ **	/ **
/ **	/ **	/ **	/ **	/ **
/	/	/	/	/

×

% **

()

rms rms
 () rpm rpm
 rms rpm rpm

()

()

rms

rms

(%)

(m/s^2)

(rpm)

/ a	/ b	/ b	/ c	/ d	/ e
/ a	/ b	/ c	/ d	/ e	/ f
/ a	/ c	/ b	/ d	/ d	/ e
/ b	/ a	/ b	/ c	/ d	/ e
/ a	/ b	/ b	/ b	/ b	/ c
/ d	/ a	/ b	/ a	/ ab	/ dc
/ a	/ b	/ c	/ d	/ e	/ f
/ a	/ b	/ c	/ d	/ e	/ f
/ d	/ b	/ a	/ c	/ e	/ f
/ bc	/ a	/ cb	/ ba	/ dc	/ d
/ c	/ a	/ b	/ d	/ e	/ f
/ a	/ ba	/ cb	/ db	/ ed	/ e
/ ed	/ cb	/ dc	/ a	/ ba	/ e
/ ab	/ a	/ ab	/ a	/ ab	/ b
/ a	/ a	/ a	/ a	/ b	/ c

)

(

()

rms

(Salokhe et al., 1995; Tewari et al., 2004)

()

(Paddan & Griffin, 2002)

a_{hv}

a_{hv}

a_{hv}

a_{hv}

a_{hv}

()

Z Y X

a_{hv}

| | | rpm
| | | | | m/s² |
| | | | | m/s²

()

a_{hv}

a_{hv}

| m/s² | | | | |

()

a_{hv} a_{hv}
 a_{hv} ()

a_{hv}

a_{hv}
 $a_{hv} (m/s^2)$

rms

:(Stikeleather, 1991)

$T_r = \frac{a_i (\text{بازو و قفسه سینه})}{a_i (\text{مشت})}$ (۳)

i

a

T_r

**	
**	
**	
%	
a_{hv}	()

x

**

T_r () ()

a_{hv}

()

rpm

rpm

a_{hv}

()

/ % / / () . % / / /

(%)		$a_{hv} (m/s^2)$			(rpm)
(a_{hv})	(a_{hv})	(a_{hv})	(a_{hv})	(a_{hv})	
/ d	/ c	/ b	/ a	/ b	
/ e	/ d	/ c	/ a	/ b	
/ e	/ d	/ c	/ a	/ b	
/ d	/ c	/ b	/ a	/ b	
/ d	/ c	/ b	/ a	/ b	
/ d	/ c	/ b	/ a	/ b	

T_r

طولی	جانبی	عمودی	دور (rpm)
۳۶/۹۶	۱۳/۴۷	۳۳/۲۹	۱۳۰۰
۳۷/۸۸	۱۶/۶	۳۲/۵۵	۱۶۰۰
۳۳/۲۰	۱۶/۱۷	۳۱/۶۲	۱۸۰۰
۳۱/۲۷	۲۱/۱۴	۱۹/۸۸	۲۰۰۰
۴۴/۲۹	۱۵/۸۵	۲۳/۰۵	۲۲۰۰
۵۳/۸۵	۱۶/۰۹	۱۵/۸	۲۴۰۰
۳۹/۵۷	۱۶/۵۵	۲۶/۰۳	میانگین

(Salokhe et al., 1995)

()

طولی	جانبی	عمودی	دور (rpm)
۱۰/۲۸	۴/۱۰	۱۰/۰۵	۱۳۰۰
۱۰/۷۷	۴/۴۲	۱۱/۱۶	۱۶۰۰
۱۰/۲۵	۴/۰۹	۹/۶۸	۱۸۰۰
۹/۱۹	۲/۲۳	۵/۱۵	۲۰۰۰
۱۰/۲۷	۲/۵۵	۴/۸۸	۲۲۰۰
۱۳/۰	۱/۹۸	۳/۸۰	۲۴۰۰
۱۰/۶۳	۳/۲۳	۷/۴۵	میانگین

:

() Salokhe et al.

()

rpm

()

%

Marsili et al.,)

(2002)

%

/

rms

(rms)

(Hansson, 2002)

Salokhe et al.

(Barber, 1992)

Paddan & Griffin,)

(2002

REFERENCES

- Anonymous, (2003). Philippine agricultural engineering standard pages 110: 2001. *Agricultural Machinery – Walking-type Agricultural Tractor – Specifications*. Part 2: Rotary Tilling-type.
- Barber, A. (1992). Handbook of Noise and Vibration Control. *Elsevier Science Publishers LTD* .6th Edition. 730pp.
- Goglia, V., Gospodari, Z., Kosutic, S. & Filipovi, D. (2003). Hand-transmitted vibration from the steering wheel to drivers of a small four-wheel drive tractor. *Applied Ergonomics*, 34,45–49.
- Hansson, P.A. (2002). Working space requirement for an agricultural tractor axle suspension. *Biosystems Engineering*, 81(1), 57-71.
- Inman, D.G. (1989). *Vibration with Control, Measurement, and Stability*. Prentice-Hall International Inc, Printed in the United States of America, P.27-182, 352pp.
- ISO 5349-1, (2001). *Mechanical Vibration—Measurement and Evaluation of Human Exposure to Hand-Transmitted Vibration—Part 1: General Requirements*, ISO, Geneva.
- ISO 5349-2, (2001). *Mechanical Vibration—Measurement and Evaluation of Human Exposure to Hand-Transmitted Vibration—Part 2: Practical Guidance for Measurement at the Workplace*.
- Kumar, A., Mahajan, P., Mohan, D. & Varghese, M. (2001). Tractor vibration severity and driver health: a study from rural India. *J. Agric. Engng Res.* 80 (4), 313-328.
- Marsili, A., Ragni, L., Santoro, G., Servadio, P. & Vassalini, G. (2002). Innovative systems to reduce vibrations on agricultural tractors: comparative analysis of acceleration transmitted through the driving seat. *Biosystems Engineering*, 81 (1), 35-47.
- Paddan, G.S, & Griffin, M.J. (2002). Evaluation of whole-body vibration in vehicles. *Journal of Sound and Vibration*, 253(1), 195-213.
- Ragni, L., Assalini, G.V., Xu, F. & Zhang, L.B. (1999). Vibration and noise of small implements for soil tillage. *J. Agric. Engng Res*, 74, 403-409.
- Rao, S.S. (1995). *Mechanical Vibration*. Third Edition. Addison Publishing Company. 1100pp.
- Rossegger, R. & Rossegger, S. (1960). Health effects of tractor driving. *J. Agric, Engng, Res*, 5, 241-275.
- Salokhe, V. M., Majumder, B. & Islam, M. S. (1995). Vibration characteristics of a power tiller. *Journal of Terramechanics*, 32, 81-197.
- Stikeleather, L.F. (1991). Seat vibration and ride comfort. In Human Factors: A series of Quality Instructional Material. *ASAE*.
- Temmerman, D. J., Deprez, K., Anthonis, J. & Ramon, H. (2004). Conceptual cab suspension system for a self-propelled agricultural machine, Part 1: Development of a linear mathematical model. *Biosystems Engineering*, 89, 409–416.
- Tewari, V. K., Dewangan, K. N. & Karmakar, S. (2004). Operator's fatigue in field operation of hand tractors. *Biosystems Engineering*, 89,1–11.