

## *Design, Implementation and Experiments on a Fish-Like Robot*

M. Siahmansouri , A. Ghanbari

### **ABSTRACT**

One of main methods for protecting nature is to use nature as an inspiration source for designing new products for human being's needs. Movement and maneuver in fluids is an important issue in human activity. In this work, by inspiration from knife fish, an undulating fin for producing propulsion force are designed and implemented. This undulating fin is a segmental anal fin, and produce sinusoidal waves which are needed for producing propulsion force. Then, parameters of this sinusoidal wave are discussed.

In the fish robot, with using a special mechanical system, the direction of propulsive force is adjustable for controlling of direction and depth of swimming. Then, details of wireless control system for maneuvering and controlling of robot `s speed are presented. Finally, the results of fish robot `s movement is discussed experimentally.

**KEYWORDS :** Biomimetic, Fish robot, Undulating fin, Controlling of direction and depth, Wireless control system, velocity Diagrams

[ ]

BCF

MPF

[ ]

MPF

[ ]

MPF BCF

( ) ( )

MPF BCF

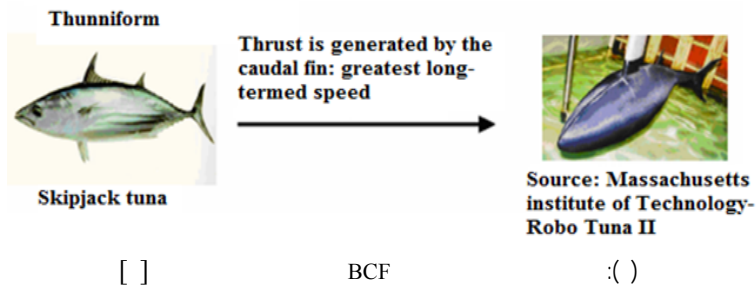

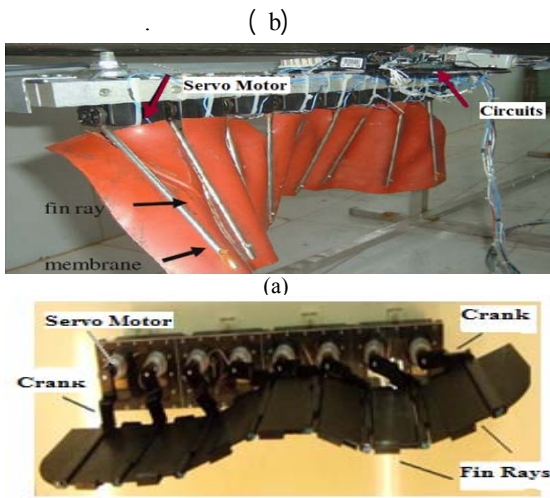

( b )

( a )

( b )

MPF

( a ) : ( )

[ ]

NKF-II

MPF

( b )

[ ]

( a )

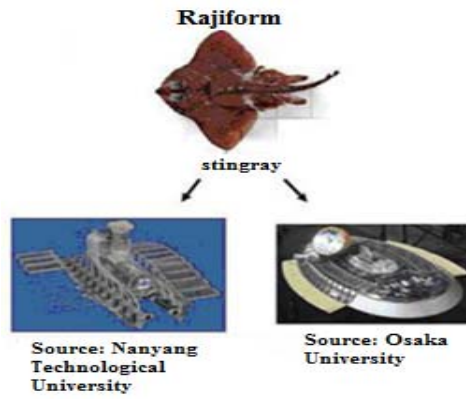

[ ]

MPF

: ( )

( )

MPF

BCF

: ( )

|     |     |   |
|-----|-----|---|
| BCF | MPF |   |
|     |     | ) |
|     |     | ( |
|     |     |   |
|     |     |   |
|     |     |   |
|     |     |   |

MPF

MPF

( b )

[ ] [ ]

( )

[ ] [ ]

( a )

( a )

[ ]

[ ] [ ]

( b )

(a) (b)

[ ] - MFP

[ ] (a) [ ]

[ ]

+

(b) ( )

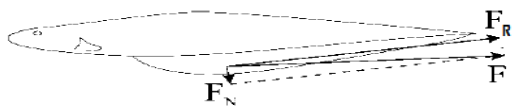

+

[ ]

( )

+

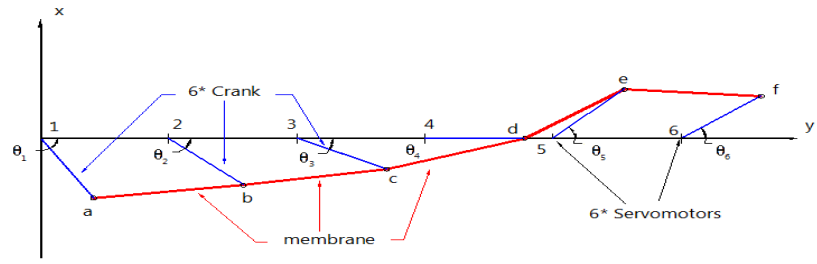

(a)

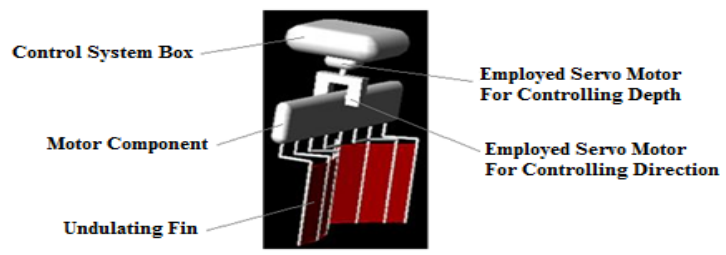

(b)

(a): ( )

(b)

( )

[ ]

LCD

[ ]

[ ]

( )

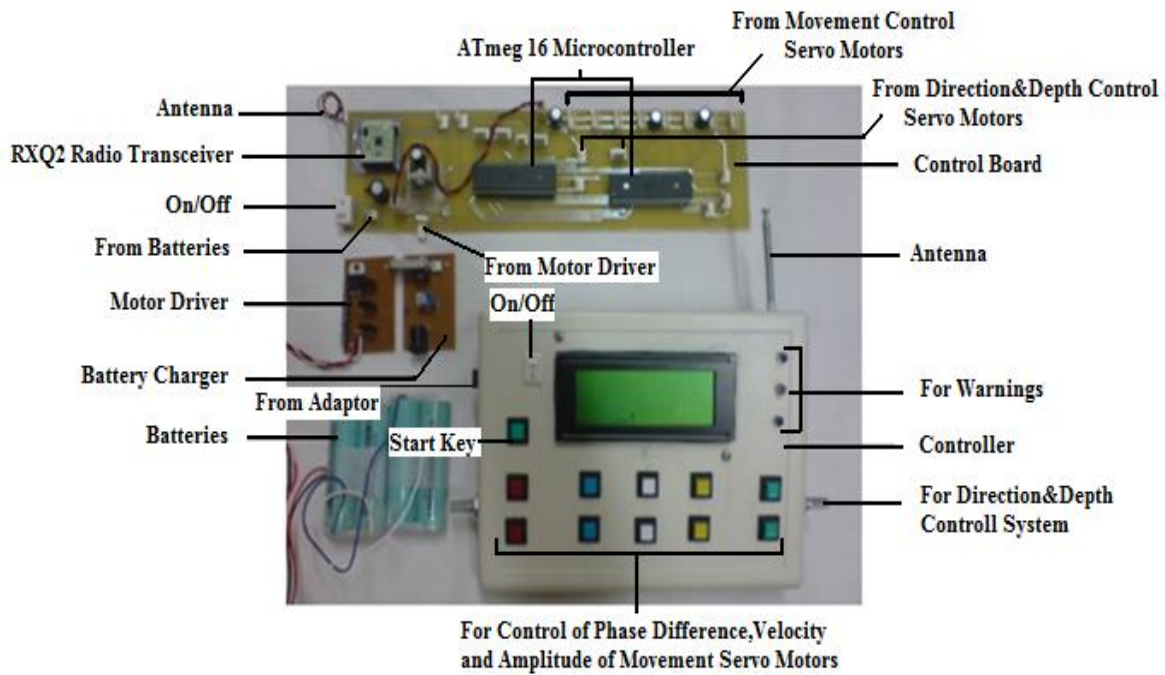

: ( )

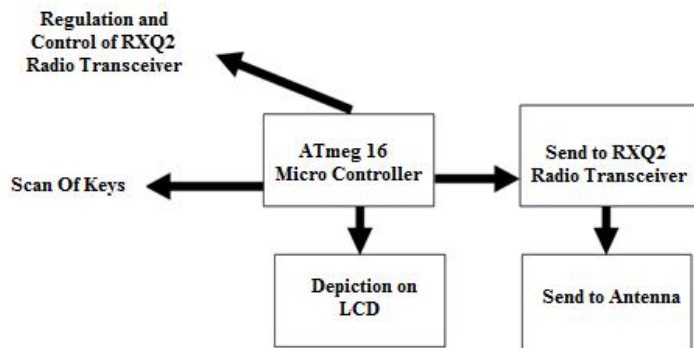

: ( )



( )

( )

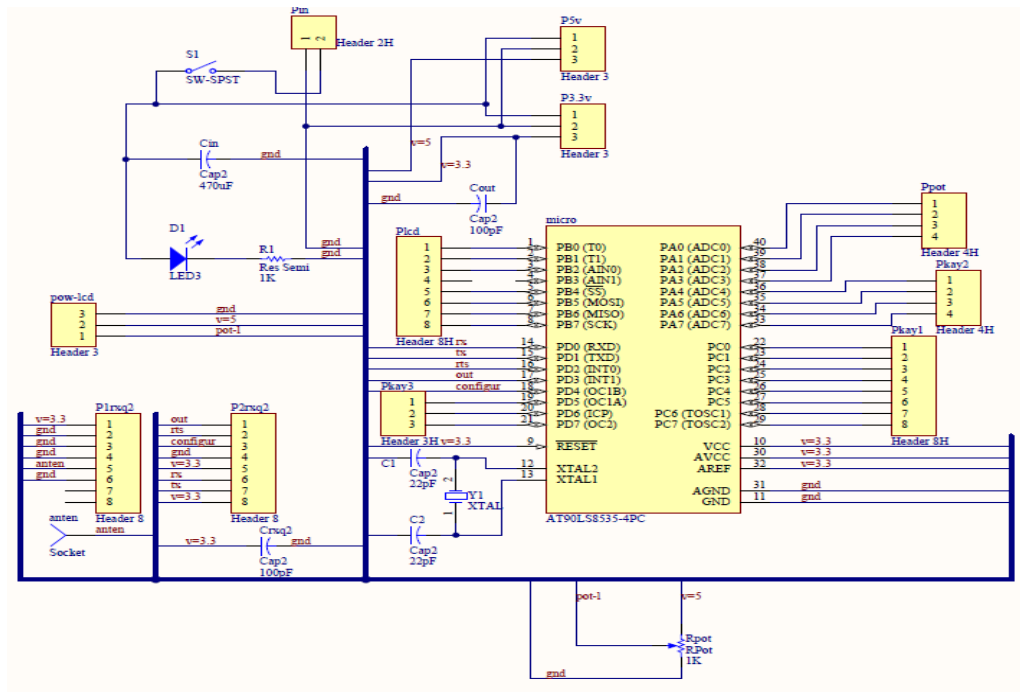

( )

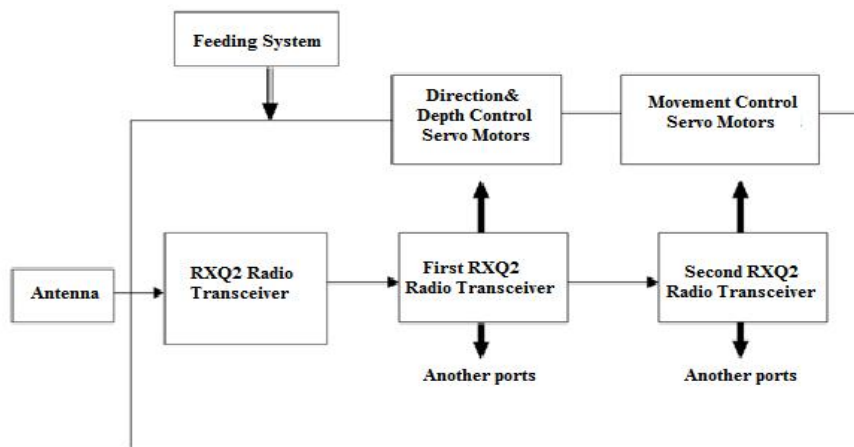

( )



/ / / /

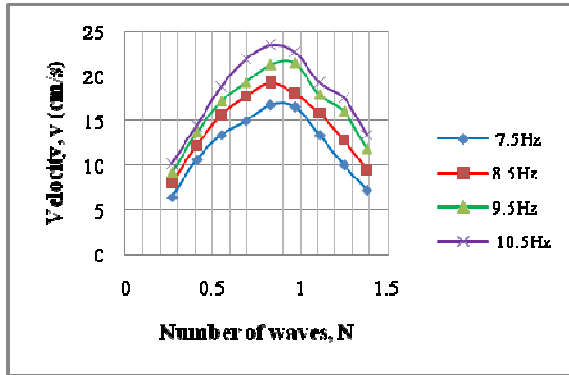

( )

$$N = \frac{\beta \cdot n_f}{360} \quad n_f = N - 1 \quad (1)$$

$\beta$

N

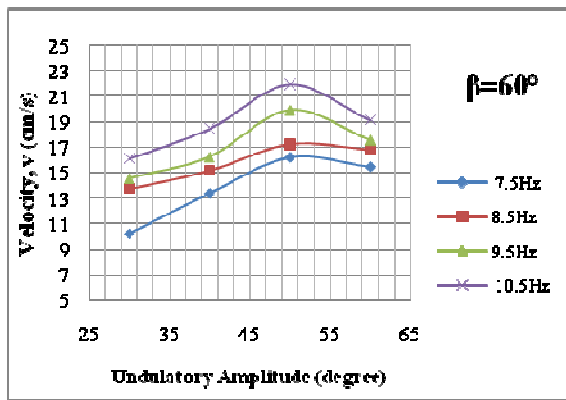

( )

$\beta = 60^\circ$

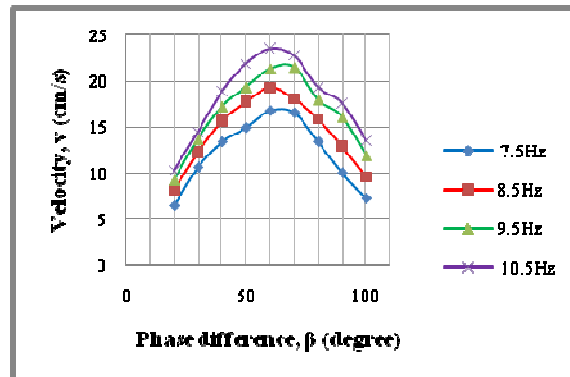

( )

( )

( )

( )

[ ]

[ ]

/

- Willy, A., Low, K. H., "Development and initial experiment of modular undulating fin for untethered biorobotic AUVs," IEEE International Conference on Robotics and Biomimetics. [ ]
- Low, K. H., Willy, A., "Biomimetic motion planning of an undulating robotic fish fin," Journal of Vibration and Control, Vol. 12, pp. 1337-1359, 2006. [ ]
- Sfakiotakis, M., Lane, D. M., Davies, J. B. C., "Review of fish swimming modes for aquatic locomotion," IEEE Journal of Oceanic Engineering, Vol. 24, pp. 237-252, 1999. [ ]
- Lauder, G. V., Drucker, E. G., "Morphology and experimental hydrodynamics of fish fin control surfaces," IEEE Journal of Oceanic Engineering, Vol. 29, pp. 556-571, 2004. [ ]
- Shao, J., Wang, L., Yu, J., "Development of an artificial fish-like robot and its application in cooperative transportation," Control Engineering Practice Vol. 16, pp. 569-584, 2008. [ ]
- Sugiyama, K., Ishii, K., Kaneto, K., "Development of an oscillating fin type actuator for underwater robots," International Congress Series, Vol. 1301, pp. 214-217, 2007. [ ]
- Wanga, Z., Hanga, G., Li, J., Wang, Y., Xiao, K., "A micro-robot fish with embedded SMA wire actuated flexible biomimetic fin," Sensors and Actuators A, Vol. 144, pp. 354-360, 2008. [ ]
- knife fish [ ]
- Low, K. H., "Modeling and parametric study of modular undulating fin rays for fish robots," Mechanism and Machine Theory, Vol. 44, pp. 615-632, 2009. [ ]
- Low, K. H., "Preface: Why biomimetic?," Mechanism and Machine Theory, Vol. 44, pp. 511-512, 2009. [ ]
- Low, K. H., "Parametric study of modular and reconfigurable robotic fish with oscillating caudal fin mechanisms," International Conference on Mechatronics and Automation, Harbin, China, 2007. [ ]
- Low, K. H., "Maneuvering of biomimetic fish by integrating a buoyancy body with modular undulating fins," International Journal of Humanoid Robotics, Vol. 4, pp. 671-695, 2007. [ ]
- Hu, T., Shen, L., Lin, L., Xu, H., "Biological inspirations, kinematics Modelling, mechanism design and experiments on an undulating robotic fin inspired by *Gymnarchus niloticus*," Mechanism and Machine Theory, Vol. 44, pp. 633-645, 2009. [ ]
- Zhang, D., Hu, D., Shen, L., Xie, H., "Design of an artificial bionic neural network to control fish-robot's locomotion," Neurocomputing, Vol. 71, pp. 648-654, 2008. [ ]
- Low, K. H., "Design, development and locomotion control of bio-fish robot with undulating anal fins," International Journal of Robotics and Automation, Vol. 22, pp. 88-99, 2007. [ ]





- 
- <sup>1</sup> Knifefish
  - <sup>2</sup> Modular
  - <sup>3</sup> Servomotor
  - <sup>4</sup> Wireless
  - <sup>5</sup> Drag force
  - <sup>6</sup> Hu, T.
  - <sup>7</sup> Zhang, D.
  - <sup>8</sup> Fin rays
  - <sup>9</sup> Low, K.H.
  - <sup>10</sup> Willy, A.
  - <sup>11</sup> Crank
  - <sup>12</sup> University of defense technology, Changsha
  - <sup>13</sup> Nanyang technological university, Singapore
  - <sup>14</sup> Slider
  - <sup>15</sup> Anal fin
  - <sup>16</sup> Pectoral fin
  - <sup>17</sup> Microcontroller
  - <sup>18</sup> Radio transceiver
  - <sup>19</sup> Genetic algorithm